

1. Assembly Diagram

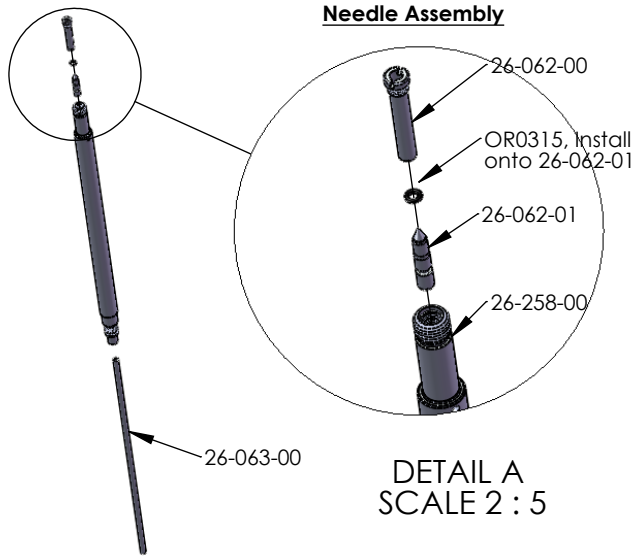

Valving Assembly

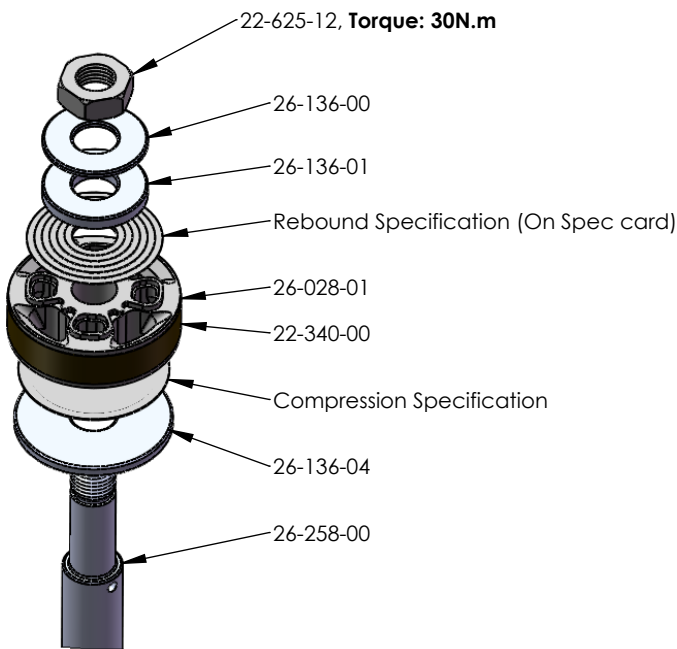

Assemblies Per Kit	1
Instructions	NO
Spec Card	YES
Packaging	Plastic Sleeve/Heatseal

Notes:

2. QC Checks

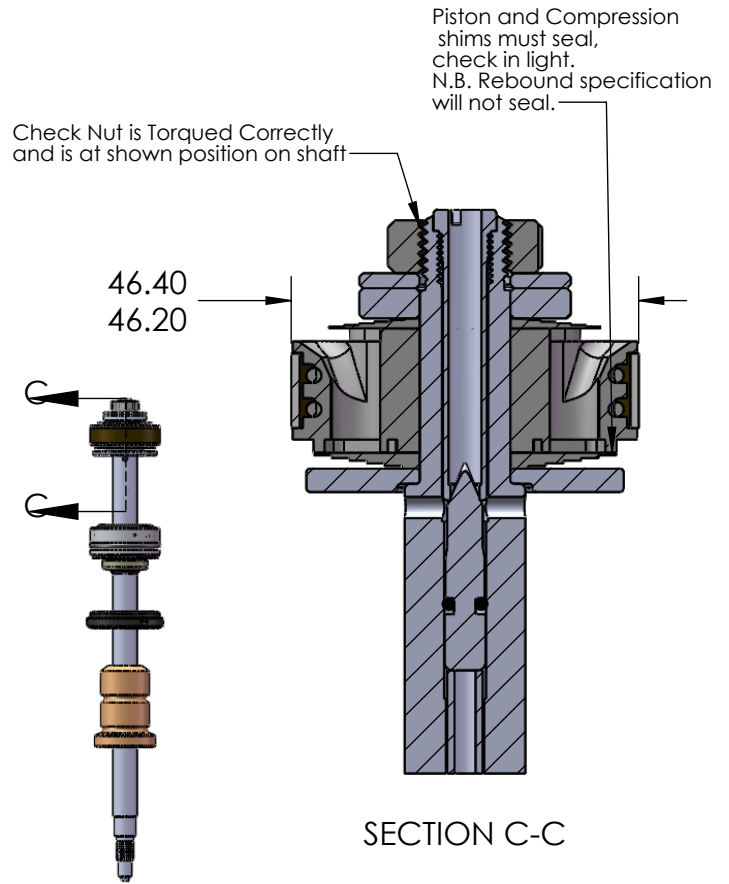

Shaft Assembly

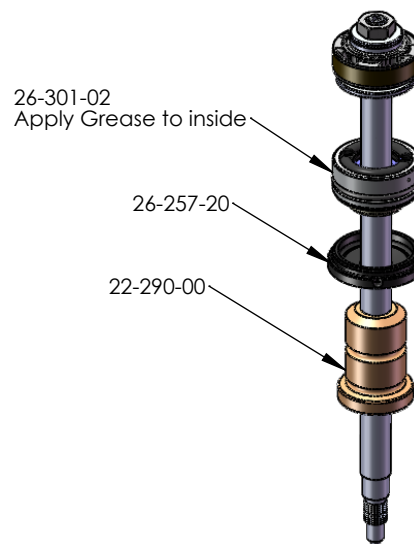

25-066-40 Build Sheet
YZ/IT Shaft Assy

PROPRIETARY AND CONFIDENTIAL

THE INFORMATION CONTAINED IN THIS DRAWING IS THE SOLE PROPERTY OF **Teknik Motorsport PTY LTD**. ANY REPRODUCTION IN PART OR AS A WHOLE WITHOUT THE WRITTEN PERMISSION OF **Teknik Motorsport PTY LTD** IS PROHIBITED.

	NAME	DATE	SIZE	DWG. NO.	REV.
DRAWN	A.Martin	28/08/2013	A4	26-066-40_Assy	
CHECKED			SCALE:1:1		SHEET 1 OF 3