



HAND COM CLICKER

MOUNTING
INSTRUCTIONS

KIT CONTENT

2 units	ADJUST ROD BY GPE
2 units	HAND COMP LEVER BY GPE
2 units	SAFETY SCREW



Follow the mounting instructions.

APPLICATION LIST

HONDA

CRF 250 15-23

CRF 450 17-23

KAWASAKI

KXF 450 15-23

SUZUKI

RMZ 450 15-23

HAND COMP CLICKER MOUNTING INSTRUCTIONS



Work

STEP 1: Close complete compression adjuster with screwdriver. N1 Clockwise. Note current setting COMP.

STEP 2: Open anti clockwise and count and note the total number of clicks.

HAND COMP CLICKER MOUNTING INSTRUCTIONS



Work

With especial tools disassembly completely the compression COMP.

HAND COMP CLICKER MOUNTING INSTRUCTIONS

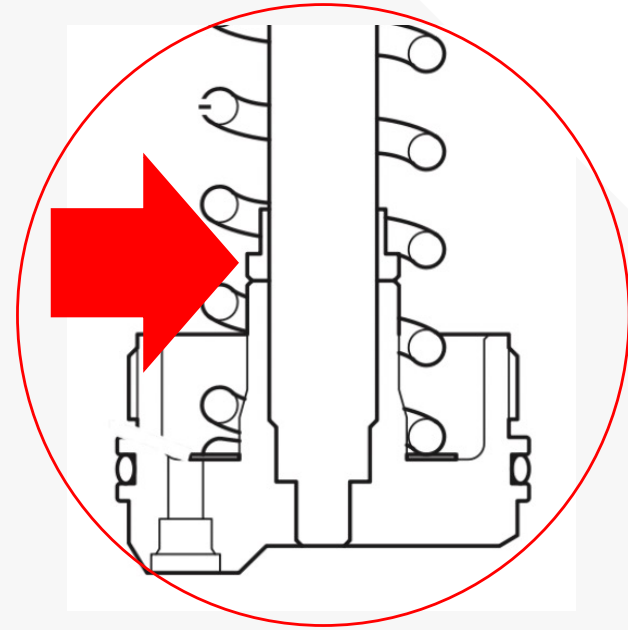
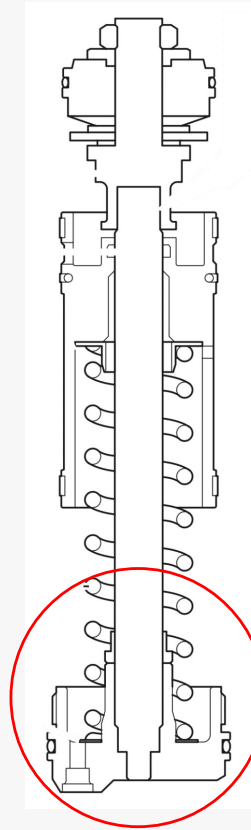

Work

Unlock completely the nut vs the top cap.



USE HOT GUN, can be safety glue applied.

HAND COMP CLICKER MOUNTING INSTRUCTIONS

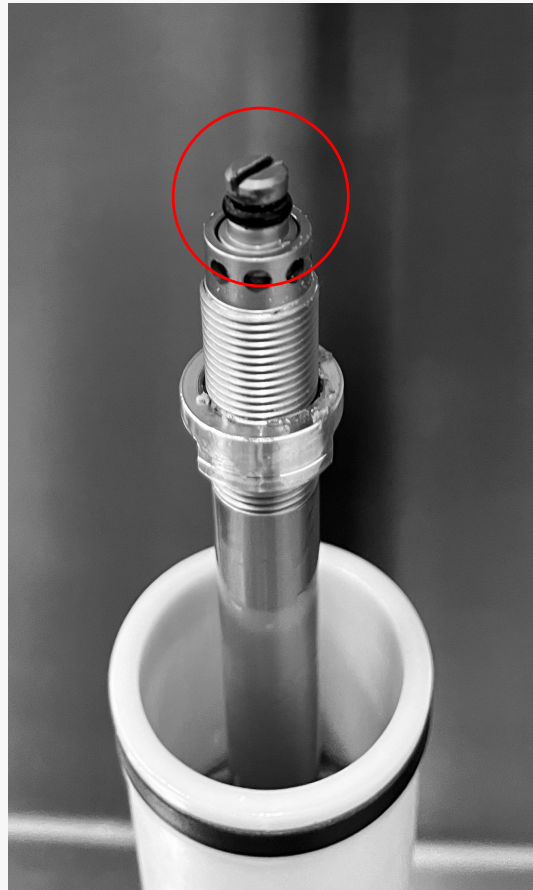

Work

Remove the STD compression adjuster.

HAND COMP CLICKER MOUNTING INSTRUCTIONS

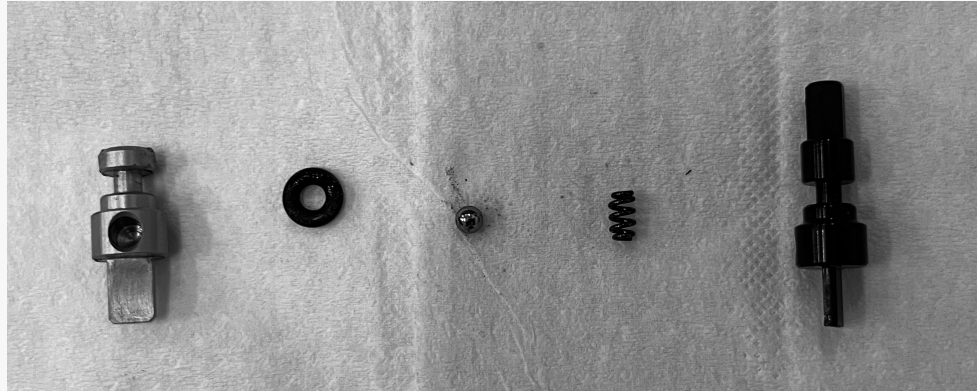

Work

Remove from the STD compression adjuster:

- O-ring
- Ball
- Spring

Install to the new ADJUST ROD B GPE.

HAND COMP CLICKER MOUNTING INSTRUCTIONS



Work

Install the new ADJUST ROD B GPE to the compression shaft.



Be sure needle shaft position is fitting correctly with the flat blade of the ADJUST ROD B.

HAND COMP CLICKER MOUNTING INSTRUCTIONS



Work

Install the fork bolt to the compression shaft.

HAND COMP CLICKER MOUNTING INSTRUCTIONS

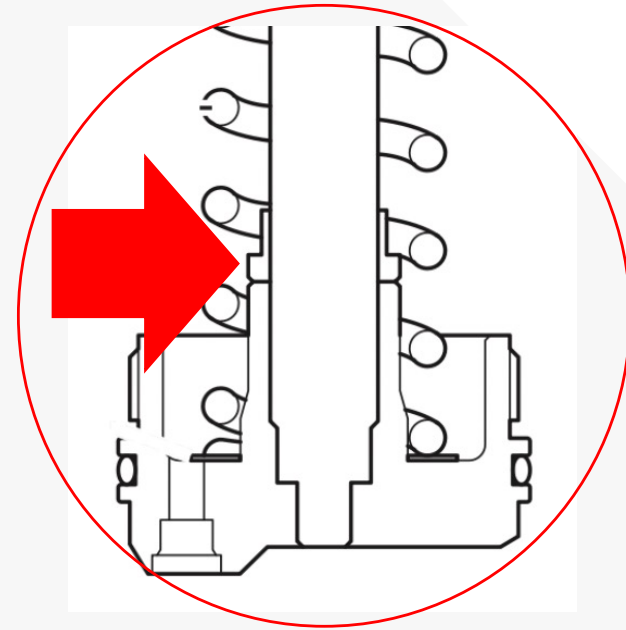
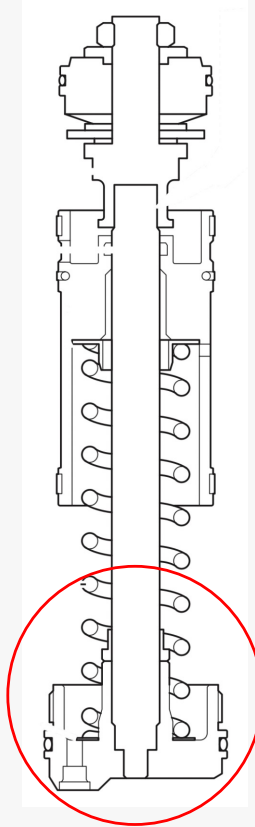

Work

Lock completely the nut vs the top cap.

TIGHTING TORQUE

SHAFT NUT -> SHAFT

$37.5 \pm 5 \text{ N} \cdot \text{m}$

HAND COMP CLICKER MOUNTING INSTRUCTIONS



Work

Install the HAND COMP LEVER and the safety screw.

HAND COMP CLICKER MOUNTING INSTRUCTIONS



Work

Check the clicker COMP adjuster is working correctly, check total number of clicks from max closed to max open.

And set the COM setting.

HAND COM CLICKER

MOUNTING INSTRUCTIONS



VERSION: 22.1

MORE INFO: contact@showabygenuinepartseurope.com